

BLY17MDA Integrated BLDC Motor/Controller Series

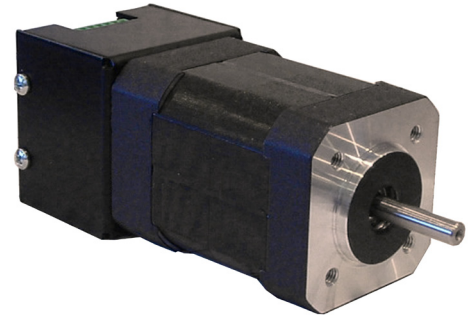

FEATURES

- Constant Velocity Mode Within 5%
- 400 - 4000 RPM Speed Range
- 0.5V to 5V External Voltage Speed Control
- 2-Quadrant Operation
- Short Circuit Protection
- Maximum Current Limit Setting at 10.0 Amps Peak
- Open Drain Speed Out
- Run/Stop and Direction Inputs
- TTL-CMOS Compatible Inputs
- Compact Size
- Screw Type Terminal Block
- Improved Closed-Loop Control
- Motor Frame: 1.7" Square



DESCRIPTION

The BLY17MDA Series is a compact construction that implements a DC Brushless controller and a DC Brushless motor in one streamline package. With the two part combined into one casing, the need to wire the motor has been eliminated. The DC Brushless controller operates off 24VDC. The high-speed DC Brushless motor can operate at 4000RPM, can generate up to 35.4 oz-in of continuous torque, and deliver as much as 105W, with the BLY17MDA4 offering. Using hall sensor feedback, the DC Brushless controller operates in a constant velocity mode within 5%. The driver is protected against over current (cycle-by-cycle), hall sensor error and under voltage. An external potentiometer (10K) or external voltage (0.5-5VDC) can be used to control the speed. The direction of the motor can be preset by the direction control input. A brake function can be done by grounding the Run/Stop input.

SPECIFICATIONS

| Model # | Rated Speed (RPM) | Torque (oz-in) | Rated Power (W) | L Length (in) | Weight (lbs) |
|---------------------|-------------------|----------------|-----------------|---------------|--------------|
| BLY17MDA1S-24V-4000 | 4000 | 8.9 | 26 | 2.975 | 0.86 |
| BLY17MDA2S-24V-4000 | 4000 | 17.7 | 52 | 3.775 | 1.24 |
| BLY17MDA3S-24V-4000 | 4000 | 26.2 | 78 | 4.575 | 1.83 |
| BLY17MDA4S-24V-4000 | 4000 | 35.4 | 105 | 5.275 | 1.96 |

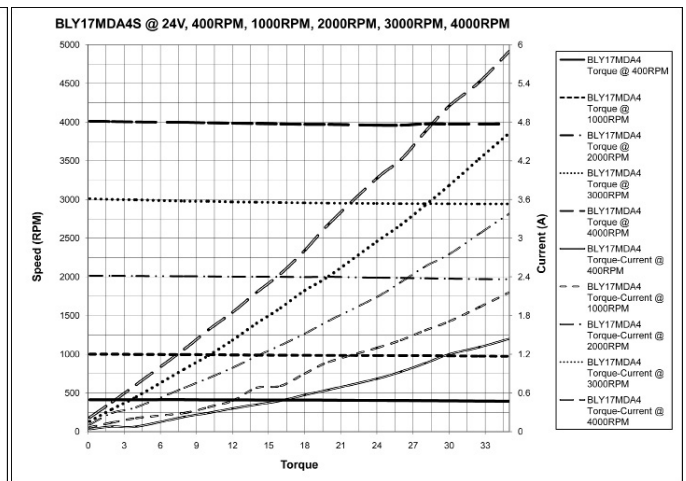
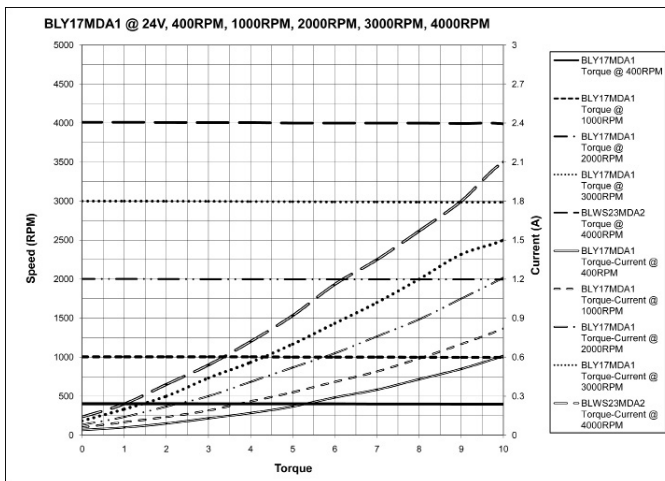

* 2 and 3 stack curves available in the user's guide

L010482

DIMENSIONS

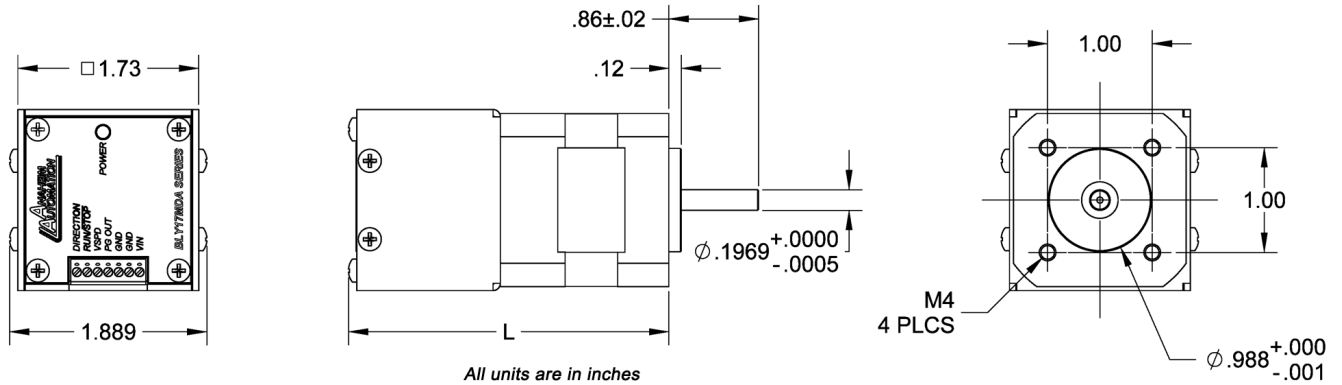

WIRING INFORMATION

| Pin # | Description |
|-------|---------------|
| 1 | Direction |
| 2 | Run/Stop |
| 3 | Vspeed |
| 4 | PG Out |
| 5 | AGND |
| 6 | PGND |
| 7 | VIN (9-35VDC) |

TB1: Power In, Control Inputs and Outputs

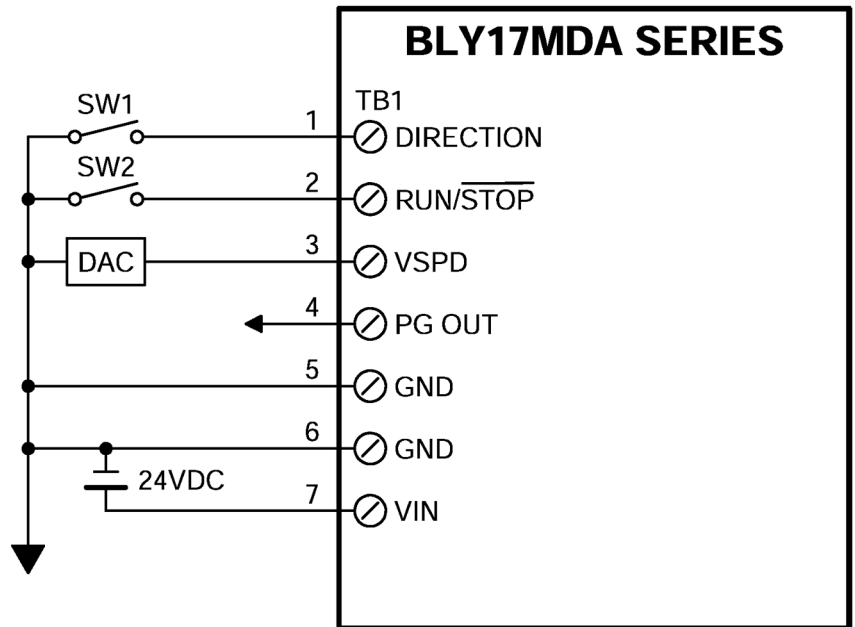

SPECIFICATIONS

| | | | |
|--------------------|-----------------------------|------------------------|------------------------------|
| Winding Type: | Delta, 8 Poles | Max Radial Force: | 6.29 lbs. @ 10mm from Flange |
| Hall Effect Angle: | 120 Degree Electrical Angle | Max Axial Force: | 2.25lbs - Force |
| Shaft Run Out: | 0.025mm | Insulation Class: | Class B |
| Radial Play: | 0.02mm@450g | Dielectric Strength: | 500VDC for one minute |
| End Play: | 0.08mm@450g | Insulation Resistance: | 100Mohm, |
| Humidity Range: | 75% (RH) non-condensing | Operating Temp. Range: | 0 - 45 degrees C |